

# VICTORIAN ELECTRICITY TRANSMISSION NETWORK CONNECTION AUGMENTATION GUIDELINES

## **MARCH 2007**

## **ISSUE NO.2**

PREPARED BY: Enter Responsible Department  
DOCUMENT NO: 292471  
VERSION NO: 2  
EFFECTIVE DATE: 28/03/2007  
ENTER STATUS: Final  
APPROVED FOR M. Zema  
DISTRIBUTION AND  
USE: Chief Executive Officer

## Version Control

VERSION	DATE CREATED	AUTHOR(S)	REVISIONS
Issue 1	19 August 2005	L Tirpcou	First operational version.
Issue 2	28 March 2007	L Tirpcou	Updated to include multi-party negotiation process

Authorised by VENCORP

Level 2 Yarra Tower, World Trade Centre, Melbourne 3005

## Table of Contents

<b>1.</b>	<b>INTRODUCTION</b>	<b>4</b>
<b>2.</b>	<b>VICTORIAN ELECTRICITY TRANSMISSION CONNECTION AUGMENTATION GUIDELINES</b>	<b>6</b>
2.1	Payment for augmentations to the shared transmission network to enable new connections	6
2.2	Additional provisions for non-scheduled generation connections	8
<b>3.</b>	<b>NEW CONNECTIONS AND AUGMENTATIONS</b>	<b>10</b>
3.1	Establishing a new connection	10
3.2	Network Augmentations	14
3.3	Issues arising from new connections and network augmentations	16
3.4	National and International Experiences	19
<b>4.</b>	<b>VENCORP'S POLICY</b>	<b>20</b>
4.1	Augmentations to meet a Chapter 5 access standard	20
4.2	Augmentations to increase the power transfer capability of the network	22
4.3	Incremental augmentations to the network	24
4.4	Non-discriminatory access to the network	27
4.5	Bringing forward augmentations and partial funding	31
<b>5.</b>	<b>WIND FARM CONNECTIONS</b>	<b>34</b>
5.1	Wind developments in the NEM	34
5.2	Wind developments and new connections	34
	<b>APPENDIX 1 NATIONAL AND INTERNATIONAL COMPARISON OF CONNECTION POLICIES</b>	<b>37</b>

## 1. INTRODUCTION

The National Electricity Rules (NER) sets out the processes and procedures that Network Service Providers (NSPs) and connection applicants must follow when a new connection to the transmission network is sought. Depending on the size, scope, timing and location of a new connection network augmentations may be required to facilitate connection to the network.

Connection augmentations may be required for one of two reasons: to ensure that a new connection complies with the NER's specified access standards for connection to the network; or to provide sufficient power transfer capability to meet the new connection's requirements. As the NSP responsible in Victoria for augmentations to the shared transmission network, VENCORP must assess and advise on issues associated with any augmentations to facilitate network connections.

While the NER sets out the processes for the consideration of technical matters during a connection process and enables a connection applicant to request a level of power transfer capability that is higher than the network's existing power transfer capability, it does not expressly address the issues of who should pay for augmentations to facilitate the network connection and how these costs are to be allocated between network users and the connection applicant.

These issues are becoming more problematic with the increasing number of large-scale wind farm development proposals which could potentially require significant network augmentations. Wind farm connections present additional issues to system security that need to be addressed by VENCORP at the time of a connection application.

To assist intending connection applicants understand these issues, VENCORP has prepared these Electricity Transmission Network Connection Augmentation Guidelines (Guidelines)<sup>1</sup>. These Guidelines aim to:

- ensure that all new connection applications are treated equitably, transparently, consistently and efficiently where practicable;
- identify the circumstances, if any, in which a new connection applicant may be required to fund an augmentation to facilitate its connection;
- identify the circumstances, if any, and timing in which VENCORP may undertake an augmentation to facilitate a new connection (in which case all network users pay);
- establish a non-discriminatory access policy for new connections; and

---

<sup>1</sup> VENCORP acknowledges the technical and legal assistance of Phillips Fox in the preparation of these Guidelines.

- set out other requirements necessary for the connection of non-scheduled generators (e.g. wind generators).

These Guidelines do not bind VENCORP. All connection enquiries must be assessed on their merits and accordingly it may be appropriate in the circumstances for VENCORP to permit connection in a manner not contemplated by these Guidelines.

VENCORP reserves the right to vary or revoke these Guidelines in whole or in part at any time at its discretion.

The structure of this document is as follows.

- Section 2 sets out VENCORP's Guidelines for the funding of augmentations associated with new connections and the additional requirements imposed on non-scheduled generators for connection to the system;

The remaining sections set out the supporting information for the development of these Guidelines:

- Section 3 summarises the relevant NER provisions relating to prospective connections, network augmentations and issues arising from augmentations for network connections;
- Section 4 sets out VENCORP's position on networks augmentations for new connections;
- Section 5 presents VENCORP's position on additional issues arising from the connection of non-scheduled generators (particularly wind farms); and
- Section 6 contains a table comparing National and International Comparison of Connection Augmentation Policies.

## **2. VICTORIAN ELECTRICITY TRANSMISSION CONNECTION AUGMENTATION GUIDELINES**

This section outlines VENCORP's principles for the funding of augmentations associated with new connections and the additional requirements imposed on non-scheduled generators for connection to the system. Section 2.1 sets out the detailed principles for the funding of augmentations associated with network connections including the situations in which a new connection applicant is required to fund its augmentation and when other network users will be required to pay for the augmentation. Section 2.2 provides the additional requirements VENCORP considers important to impose on non-scheduled generators for the purposes of maintaining the integrity of the network. These Guidelines should be read in conjunction with Chapter 4 of this document.

### **2.1 Payment for augmentations to the shared transmission network to enable new connections**

1. Augmentations to increase the power transfer capability of the network will be defined to be augmentations which are not required to facilitate a network connection to meet either an automatic, minimum or negotiated access standard as specified in schedule 5.2 or 5.3, as appropriate, of the NER.
2. A connection applicant will fund any augmentations necessary to enable its connection to meet an automatic, minimum or negotiated access standard. The requirements of the funded augmentation provisions of the NER must be met in respect of such an augmentation.
3. The funding of an augmentation by a connection applicant does not provide that connection applicant with any additional (firm financial or physical) rights of access to the network.
4. When an increase in the power transfer capability of the network is requested in a connection application, VENCORP, based on good engineering practices, may elect to undertake a preliminary assessment as to whether an augmentation to achieve that increase in power transfer capability is likely to satisfy the regulatory test. The connection applicant will fund the preliminary assessment.
5. If the preliminary assessment indicates that the augmentation is:
  - a. reasonably likely to satisfy the regulatory test, VENCORP may elect to proceed with an assessment of the augmentation against the regulatory test in accordance with the provisions of clause 5.6 of the NER; or

- b. unlikely to satisfy the regulatory test, the connection applicant will have the option of funding the augmentation, subject to the satisfaction of the requirements of the funded augmentation provisions of the NER.
6. Subject to the preliminary program agreed by VENCORP and the connection applicant, if in VENCORP's reasonable opinion additional augmentation works over and above those comprising the network augmentation may satisfy the regulatory test which would suffice to:
- a. ensure a new connection applicant satisfies either a minimum, automatic or negotiated access standard; or
  - b. increase the power transfer capability of the system to the level requested by a new connection applicant,

VENCORP may apply the regulatory test to the costs and market benefits of that incremental augmentation.

- 7. Where an incremental augmentation is constructed, which is comprised of works that are not required by a connection applicant, the connection applicant will fund only such costs as are associated with the augmentation works that facilitate its connection.
- 8. It may be fair and reasonable for VENCORP to require as a term of connection that a connection applicant ('Connection Applicant 2') contribute to the costs of an augmentation funded by an earlier connection applicant ('Connection Applicant 1') in a fair and reasonable manner, where Connection Applicant 2 utilises that augmentation to ensure it meets an automatic, negotiated or minimum access standard.
- 9. Where VENCORP did so require, it would likely limit the imposition on Connection Applicant 2 of any obligation to contribute to the costs of augmentation to circumstances in which Connection Applicant 2 connects within a period of three years from the augmentation's commissioning date.
- 10. It would not be appropriate for VENCORP to adopt an analogous course in respect of any augmentation to increase power transfer capability funded by Connection Applicant 1 that benefits Connection Applicant 2 other than in respect of meeting an automatic, negotiated or minimum access standard.
- 11. VENCORP may assist two or more connection applicants to reach mutually beneficial commercial arrangements to fund an augmentation where each connection applicant consents to VENCORP disclosing limited information regarding the intended location, size, scope and timing of its proposed new connection to the other new connection applicant(s).
- 11A. Where VENCORP receives two or more applications to connect to the shared transmission network in a similar location within a similar timeframe, and a funded augmentation is required to facilitate any connection in that location, VENCORP will give

the applicants the opportunity to decide how to allocate the augmentation costs via a multi-party negotiation process. VENCORP will offer a three month negotiation period in which to agree a proposal for allocation of the augmentation costs, to run from receipt of the second connection application or (if later) when the scope of works and cost estimate for the augmentation has been determined. If agreed, further applicants during the negotiation period may join the process.

- 11B. If the applicants do not agree to the multi-party negotiation process or the negotiations fail, VENCORP may make offers to connect which include a cost allocation methodology determined by VENCORP on a fair and reasonable basis, to apply in the event that multiple parties accept a connection offer by a specified date. This methodology may involve a fixed portion (e.g. based on installed capacity (MW)) and variable portion (e.g. based on energy consumed (MWh)).
12. VENCORP may consider bringing forward an identified network augmentation on the request of a connection applicant, provided:
- a. bringing forward the augmentation does not result in any cost or risk to the market, and
  - b. VENCORP can fully recover the costs, at no risk, of the brought forward augmentation.
13. One approach that VENCORP may consider further is bringing forward the augmentation on the basis that the connection applicant meets any net costs associated with bringing the augmentation forward. In this instance, other network users would be indifferent between the augmentation being constructed at the original date forecast by VENCORP and the brought forward date.

## **2.2 Additional provisions for non-scheduled generation connections**

14. A non-scheduled generator will be required by its connection agreement to install generation control equipment if VENCORP deems it appropriate to ensure that the power system continues to operate securely and reliably.
15. The terms of the non-scheduled generator's connection agreement will establish arrangements for managing network use on a fair and reasonable basis, if the combined generating capacity of the non-scheduled generators exceed, or is reasonably likely at some future time to exceed, the power transfer capability of the line to which they are or will be connected. In particular, these arrangements may provide for the generation of competing non-scheduled generators to be reduced on a fair and reasonable basis where their combined output would otherwise exceed the power transfer capability of the line to which they are connected.

The main elements of these Guidelines are captured in the following flow chart.

FIGURE 1 PAYMENT FOR AUGMENTATIONS TO THE SHARED TRANSMISSION NETWORK FOR NEW CONNECTIONS

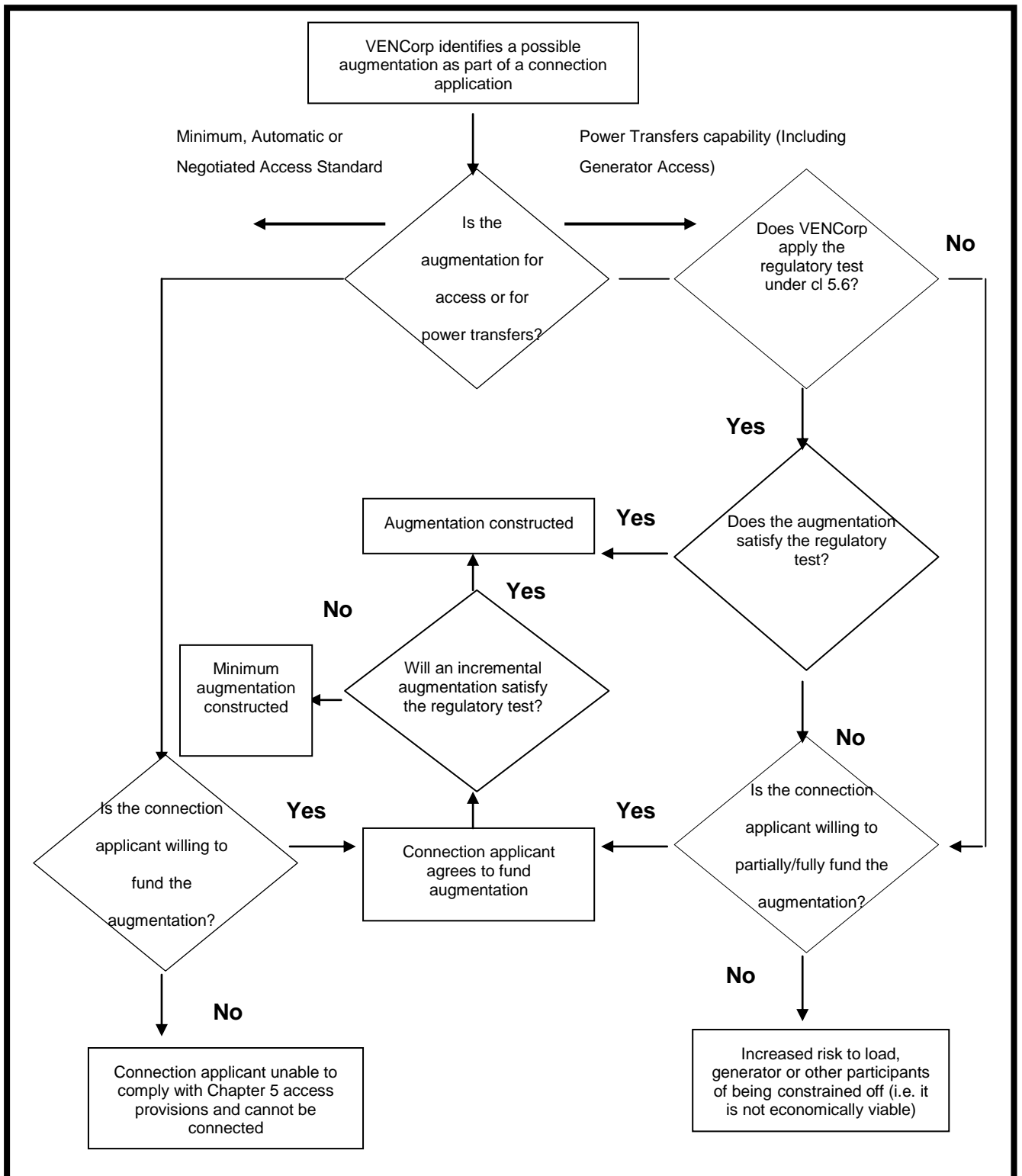

### 3. NEW CONNECTIONS AND AUGMENTATIONS

#### 3.1 Establishing a new connection

A principle underlying new connections to a network is to provide all parties with the opportunity to form a connection to and have access to a network<sup>2</sup>. The terms and conditions of that connection must be fair and reasonable and agreed between the NSP and the intending connection applicant.

The NER contains a number of processes that a connection applicant and NSP must follow when a new connection, or modification of an existing connection, is sought<sup>3</sup>. These processes, and associated headings under which they appear in the NER, are outlined in Figure 2.

---

<sup>2</sup> Clause 5.1.3 National Electricity Rules

<sup>3</sup> In Victoria a connection applicant may be required to submit a connection enquiry to both VENCORP and the relevant asset owner depending on the location of the network connection. Clause 9.7.2 of the Jurisdictional Derogation for Victoria sets out whether VENCORP or the relevant asset owner (called the connection service provider) is required to process and respond to a connection enquiry.

FIGURE 2 PROCESS FOR ESTABLISHING OR MODIFYING A CONNECTION

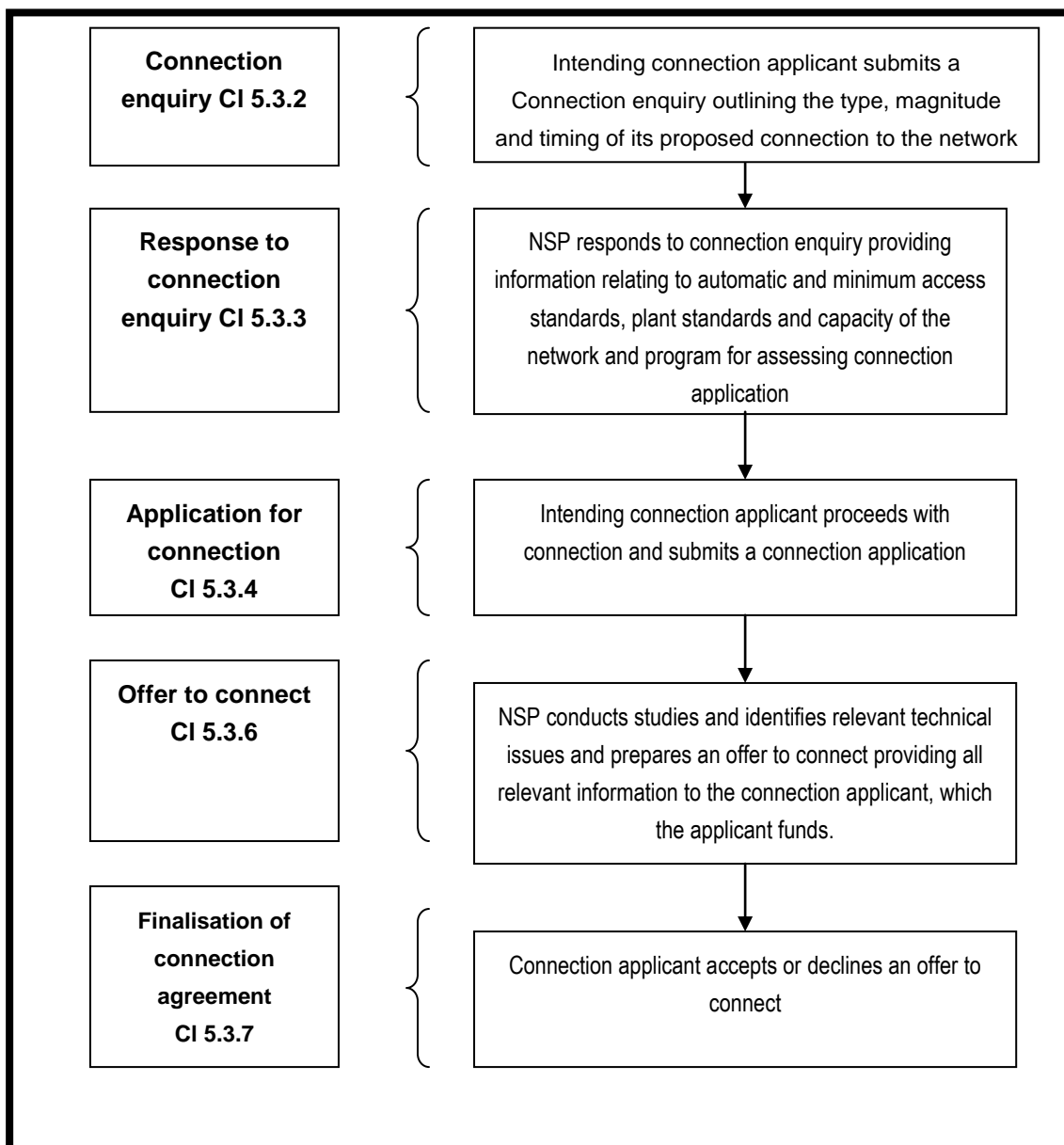

The two most extensive processes for the intending connection applicant and the NSP when establishing or modifying a connection are the connection enquiry and connection application processes.

A connection enquiry requires an intending applicant to advise the NSP of the type, magnitude and timing of its proposed connection to the network.

In response to a connection enquiry the NSP must provide the intending applicant information setting out:

- a preliminary program for that connection;
- the automatic access standards;
- the minimum access standards;
- plant standards for connection to the network (if applicable);
- details of the reasonable level of power transfer capability that the network will provide; and
- indicative technical issues

The technical terms and conditions of connection agreements, such as standards or performance, are set out in the schedules to Chapter 5 of the NER. Schedules 5.2 and 5.3 of the NER set out the automatic access standards and minimum access standards which cover the following matters<sup>4</sup>:

- Design standards
- Protection systems and settings;
- Settings of protection and control systems;
- Power factor requirements;
- Voltage fluctuations;
- Harmonics and voltage notching; and
- Design requirements for substations.

Following receipt of the responses from a NSP an intending applicant can proceed with its application to connect providing the application contains all relevant information required and specified by the NSP in response to the connection enquiry. The NSP must then assess the connection application in the timeframe set out in the preliminary program.

Should a connection applicant not be able meet, or not seek a connection at, the automatic access standards that connection applicant must apply for a negotiated access standard. An NSP must accept a negotiated access standard providing that the negotiated standard is not

---

<sup>4</sup> The NER defines an automatic access standard as a technical requirement of access, a standard of performance, identified in a schedule of Chapter 5 as an automatic access standard for that technical requirement, such that a *plant* that meets that standard would not be denied access because of that technical requirement. It defines a minimum access standards as a technical requirement of access, a standard of performance, identified in a schedule of Chapter 5 as a minimum access standard for that technical requirement, such that a *plant* that does not meet that standard will be denied access because of that technical requirement.

below the minimum access standard and does not have the potential to adversely affect power system security or the quality of supply for other network users.

Typically, the trade off between a connection at the automatic access standard and another access standard is that the cost of connection at another standard may be reduced, particularly if it is at the minimum standard, but the negotiation process is more protracted as it involves negotiations with both the NSP and NEMMCO.

Providing that all matters above are reasonably satisfied the NSP will submit an offer to connect to the connection applicant.

The offer to connect must:

- contain the proposed terms and conditions for connecting to the network, including for each technical requirement, the automatic access standard or the accepted negotiated access standard<sup>5</sup>; and
- be fair and reasonable and consistent with the safe and reliable operation of the power system in accordance with the NER<sup>6</sup>.

The NSP must use its reasonable endeavours to provide the connection applicant with an offer to connect which includes the location of the proposed connection point and the level and standard of power transfer capability that the network will provide<sup>7</sup>.

In addition to the provisions governing establishing or modifying a connection, the NER enables generators to negotiate 'generator access arrangements' with the NSP<sup>8</sup>. Generator access arrangements are not an automatic outcome of the connection process set out above.

The NER specifies that generator access arrangements may include terms in respect of:

- the amount to be paid by the generator to the NSP in relation to the costs reasonably incurred by the NSP in providing generator access;
- compensation to be provided by the NSP to the generator in the event that the generating units or group of 'generating units' of the generator are 'constrained off' or 'constrained on' during a 'trading interval'; and
- compensation to be provided by the generator to the NSP in the event that 'dispatch' of the generator's 'generating units' causes another generator's 'generating units' or group of 'generating units' to be 'constrained off' or 'constrained on' during a trading interval<sup>9</sup>.

---

<sup>5</sup> Clause 5.3.6(b) of the NER.

<sup>6</sup> Clause 5.3.6(c) of the NER.

<sup>7</sup> Clause 5.3.6(d) of the NER.

<sup>8</sup> Clause 5.5 of the NER.

<sup>9</sup> Clause 5.5(f) of the NER.

VENCorp has not set out its approach to the negotiation of 'generator access' in these Guidelines.

### 3.2 Network Augmentations

A prospective connection applicant may request, or the NSP may identify the need for, an augmentation to the shared transmission network for one of two reasons:

- to ensure compliance with either an automatic or negotiated access standard; and/or
- to enhance the power transfer capability of the network<sup>10</sup> (augmentations to the network's power transfer capability may be requested by a prospective generator to ensure that its available generation capacity is able to be dispatched, or by a prospective load to improve the reliability level).

For the purpose of these Guidelines augmentations to increase the power transfer capability of the network will be defined to be augmentations which are not required to facilitate a network connection to meet either an automatic, minimum or negotiated access standard as specified in schedule 5.2 or 5.3, as appropriate, of the NER.

While the NER sets out the technical standards necessary for a connection applicant to connect to the shared transmission network and enables a connection applicant to request a level of power transfer capability that is higher than the network's existing power transfer capability, it does not require a NSP to undertake an augmentation to facilitate that connection<sup>11</sup>. Nor does it expressly require the connection applicant to pay the costs of such a network augmentation.

However, it may be fair and reasonable for a NSP to require the connection applicant to pay the costs of augmentation where:

- the connection does not meet an automatic access standard(s); and
- the augmentation is necessary to ensure the connection meets the minimum access standard and does not adversely affect power system security or the quality of supply for other network users.

---

<sup>10</sup> Power transfers are defined in the NER as the instantaneous rate at which active energy is transferred between connection points.

<sup>11</sup> Clause 5.3.6(k) states that nothing in the NER is to be read or construed as imposing an obligation on a Network Service Provider to effect an extension of a network unless that extension is required to effect or facilitate the connection of a Connection Applicant and the connection is the subject of a connection agreement

Further, a connection applicant may elect to pay the costs of an augmentation required to provide connection at the requested level of power transfer capability. In both of these cases, the augmentation is a 'funded augmentation' and the NSP must follow the consultation process set out in clause 5.6.6B of the NER prior to carrying out the augmentation work.

The NER requires NSPs to plan, design, maintain and operate their networks to allow the transfer of power from generators to customers under system normal conditions and under certain credible contingencies, during which the power transfer capability can range from zero to full capacity<sup>12</sup>. Accordingly, VENCORP may carry out network augmentations where necessary to meet its NER obligations in respect of planning and development of the network.

Based on these provisions, VENCORP plans the transmission network to ensure that following the loss of the most critical transmission element, including at times of peak demand:

- the security of the power system can be maintained;
- transmission plant ratings are not exceeded; and
- the network performance requirements in Schedule 5.1 of the NER are met<sup>13</sup>.

Where VENCORP believes this may be violated it will consider a range of options to address the identified need and apply the regulatory test. The regulatory test is a cost-benefit analysis used by NSPs in the NEM to assess the economic viability of augmentations to the network<sup>14</sup>.

Where a project is demonstrated to satisfy the regulatory test VENCORP will normally proceed with the augmentation. Where such an augmentation is justified under the regulatory test the costs will be levied on network users in accordance with the provisions of Chapter 6 of the NER.

---

<sup>12</sup> National Electricity Rules, Schedule 5.1.2.

<sup>13</sup> VENCORP, Electricity Transmission Network Planning Criteria, July 2003.

<sup>14</sup> The essential elements of the regulatory test are contained in Note 1 of the Regulatory Test document which states:

- (1) An option satisfies the *regulatory test* if:
- a. in the event the option is necessitated solely by the inability to meet the minimum network performance requirements set out in schedule 5.1 of the Rules or in relevant legislation, regulations or any statutory instrument of a participating jurisdiction - the option minimises the present value of costs, compared with a number of alternative options in a majority of reasonable scenarios;
  - b. in all other cases - the option maximises the expected net present value of the *market benefit* (or in other words the present value of the *market benefit* less the present value of *costs*) compared with a number of *alternative options* and timings, in a majority of *reasonable scenarios*.

The Regulatory Test document contains six pages of explanatory notes setting out how the test should be interpreted.

However, there is no express relationship between the NER's requirements for a NSP to identify the need for augmentation, and thereby assess proposed augmentations against the regulatory test, and those NER provisions governing network connections.

### **3.3 Issues arising from new connections and network augmentations**

Substantial investment in network assets may be required if new generation or load connects at congested locations on the network. While it is appropriate for a connection applicant to face locational investment signals, particularly given that the network pricing arrangements do not provide adequate signals for new connections, it is also important that all prospective connections are treated equitably as far as possible. In this regard, questions arise as to whether it is appropriate for a new connection applicant to bear all augmentation costs, especially if that connection is the "straw that breaks the camel's back".

Potential difficulties arise where the performance of the network gradually approaches the limits of acceptable performance over time. In general, there are two alternative situations that may arise.

- The network has adequate capability, be it to meet the access standards or power transfer capability, to accommodate a limited number of new connections without service quality being degraded unacceptably; or
- The network is nearing its performance limit, and a new connection will trigger the need for a network augmentation.

A simplified example of the situation described above is set out in Figure 3.

FIGURE 3 SIMPLIFIED EXAMPLE OF A NETWORK AUGMENTATION FOR A NEW CONNECTION TO INCREASE THE POWER TRANSFER CAPABILITY

Assume initially an existing network with a power transfer capability of 500MW. There is only one generator (Incumbent Generator) able to produce 200MW of electricity. Demand in the market is 200MW. Given the capacity of the network and the size of the demand the Incumbent Generator is able to produce at full capacity and to satisfy the market demand without encountering any constraint on its output.

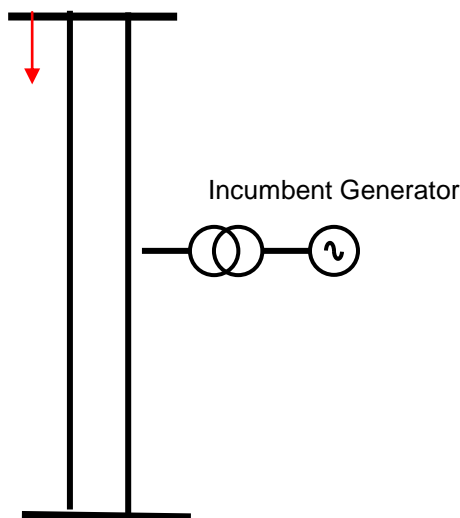

<b>Network Power Transfer capability</b>	
500MW	
<b>Supply:</b>	
Incumbent Generator:	200MW
<b>Demand</b>	
200MW	

Assume now that load grows by 200MW. In response to the increase in demand, a new generator of 350MW enters the market, Entrant Generator. Now, both generators operating at full capacity will exceed the power transfer capability of the network. To ensure that all generators are able to operate at full capacity a network augmentation is now required. Examples of the augmentations that either one of the generators may consider could involve the installation of Series Capacitors or a third line.

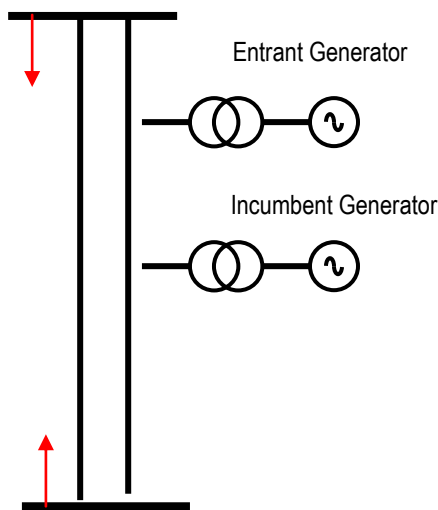

<b>Network Power Transfer capability</b>	
500MW	
<b>Supply:</b>	
Capacity of Incumbent Generator:	200MW
Capacity of Entrant Generator	350MW
<b>Demand:</b>	
400MW	

The example in Figure 3 depicts a situation where a connection applicant may request an augmentation because the power transfer capability of the network will be inadequate to enable all generators to operate at full capacity following the new connection.

However, an augmentation may also be required to facilitate connection where newly connecting generators, or loads, are unable to meet the appropriate access standards due to inadequate network capacity. An example of this is outlined in Figure 4.

**FIGURE 4 SIMPLIFIED EXAMPLE OF A NETWORK AUGMENTATION FOR A NEW CONNECTION TO MEET THE ACCESS STANDARD**

Assume initially a length of line (line 2) with a power transfer capability of 100MW in either direction. There are no generators connected to the line. Demand is connected to Bus A and supplied via line 1.

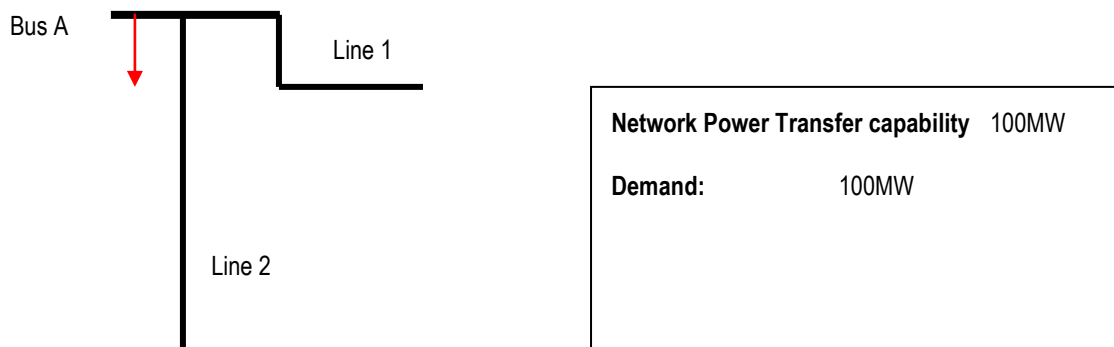

Assume now that a 100MW generator connects to Bus B. Following its connection the voltage level will vary by 15 per cent at Bus A for changes in the generators output from zero to full output (eg gas fired or wind generator). This will be unacceptable and violate the automatic access standard for voltage levels. To maintain the voltage profile an augmentation is required. There are a number of augmentations which may restore the voltage level including wider reactor tap ranges, replacing plant such as circuit breakers, capacitor bank, an SVC or a parallel line-to-line 2.

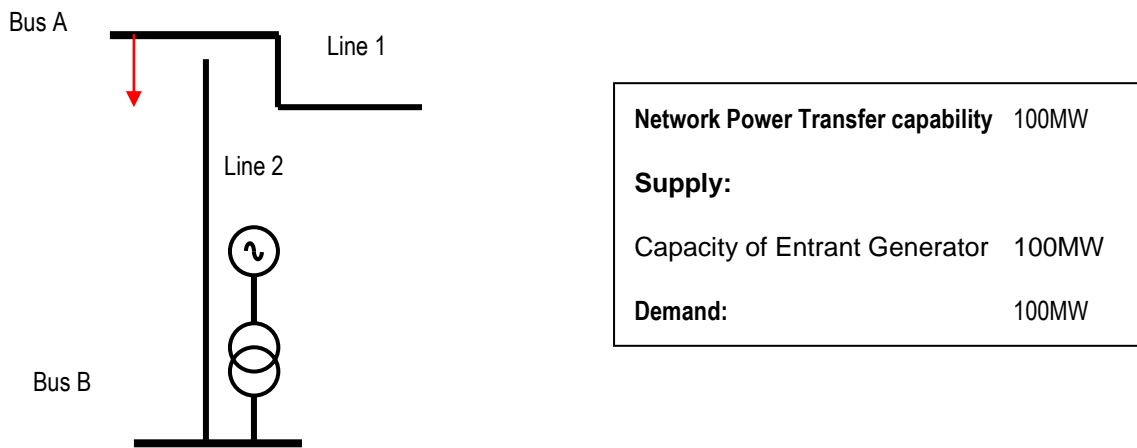

While the examples depicted in Figures 3 and 4 deal with issues arising from the connection of a new generator similar issues can be presented by the connection of a new load.

The possibility of a new connection triggering the need for network augmentation raises questions as to who should fund the cost of that augmentation and when should it be undertaken. VENCORP's approach to these issues is set out in Section 4.

### **3.4 National and International Experiences**

Both domestically and internationally, the approach adopted by regulatory agencies and NSPs to the issues arising from new connections differ. In some cases, (e.g. UK) a shallow connection policy is preferred with connecting parties (load and generation) charged only for connection assets, which includes any assets that are affected by the requirement for connections. Other jurisdictions (e.g. US, Canada) adopt a deeper connection policy with users paying for all costs necessary to accommodate network connection including embedded augmentations.

From the point of view of network queuing, those with established queuing policies (e.g. US) typically treat new connections on a first come-first serve basis. However, in light of the number of new wind farm connections, studies can be conducted in a 'cluster'. The cluster is based on requests made within a window of 180 days. This allows the NSP to undertake system design studies dealing with all the applications with the same design, rather than serially.

For the connection of non-scheduled generators (e.g. wind farms), as in Australia, international regulatory agencies are reviewing whether the technical requirements for the connection of significant wind generators are sufficient to maintain the safety and security of the network.

Appendix 1 presents a table summarising a review undertaken by VENCORP of national and international approaches to new connections.

## 4. VENCORP'S POLICY

### 4.1 Augmentations to meet a Chapter 5 access standard

In this chapter each numbered statement in a box aligns with the Guideline set out in Section 2.

1. **Augmentations to increase the power transfer capability of the network will be defined to be augmentations which are not required to facilitate a network connection to meet either an automatic, minimum or negotiated access standard as specified in schedule 5.2 or 5.3, as appropriate, of the NER.**
2. **A connection applicant will fund any augmentations necessary to enable its connection to meet an automatic, minimum or negotiated access standard. The requirements of the funded augmentation provisions of the NER must be met in respect of such an augmentation.**
3. **The funding of any augmentation by a connection applicant does not provide that connection applicant with any additional (firm financial or physical) rights of access to the network.**

If an augmentation is required to facilitate a new connection to meet an automatic, minimum or negotiated access standard, the connection applicant should fund that augmentation<sup>15</sup>. This is appropriate for a number of reasons.

First, there is no express provision in the NER which compels VENCORP to augment the network to facilitate a new connection.

Second, the NER requires connection applicants to meet either the automatic access standard or a negotiated access standard applicable to each technical requirement for connection, if VENCORP is to grant connection. A connection applicant must seek connection at a negotiated access standard where it is unable to satisfy the automatic access standard in respect of each technical requirement<sup>16</sup>. VENCORP must reject a negotiated access

---

<sup>15</sup> If a connection applicant agrees to pay the costs of augmentation necessary to effect or facilitate connection, the augmentation is a 'funded augmentation' and VENCORP must follow the consultation process set out in clause 5.6.6B of the NEC prior to carrying out the augmentation work.

<sup>16</sup> Clause 5.3.4 of the NER provides that for each technical requirement where the proposed arrangement will not meet the automatic access standards nominated by the NSP, the connection applicant must submit with the application to connect a proposal for a negotiated access standard for each such requirement determined in accordance with clause 5.3.4.A.

standard where that standard is below the minimum access standard or has the potential to adversely affect power system security or the quality of supply to other network users<sup>17</sup>. Where augmentation is necessary to enable the connection to meet the minimum access standard and to ensure the connection does not adversely affect power system security or the quality of supply to other network users, it would likely be 'fair and reasonable' for VENCORP to include in an offer to connect a term requiring the connection applicant to pay any costs reasonably required to ensure such effects do not occur<sup>18</sup>.

Third, requiring a connection applicant to fund an augmentation to facilitate its connection to meet the access standards provides appropriate economic signals for locational decisions, particularly for generators, which are currently not provided under the network pricing provisions of the NER.

Finally, the costs associated with that augmentation would not otherwise have been incurred if not for the new connection.

It is important to note that the funding of the augmentation to meet an access standard will not guarantee the connection applicant any (firm financial or physical) rights over the use of those assets. The NER does not provide a network user any physical rights over network assets. While the ACCC's NEM Access Code Decision<sup>19</sup> discusses connection and use of system arrangements in some detail, including "firm access", it does not contemplate the provision of physical firm access at any point. Therefore, as with the use of other shared network assets new connections will compete with other network users located along the network for the available network capacity.

Should the connection applicant not agree to fund the necessary augmentation to meet the relevant access standard(s), VENCORP cannot provide the intending connection applicant with an offer to connect as the connection application will not otherwise satisfy the technical requirements for connection established by the NER.

---

<sup>17</sup> Clause 5.3.4A(d) of the NER.

<sup>18</sup> Clause 5.3.6(c) requires the offer to connect to be fair and reasonable and consistent with the safe and reliable operation of the power system in accordance with the NER.

<sup>19</sup> Australian Competition and Consumer Commission, Decision: Application for acceptance National Electricity Market Access Code, 16 September 1998.

## 4.2 Augmentations to increase the power transfer capability of the network

A connection applicant may request a particular level of power transfer capability as a term of connection or, in the case of a generator, generator access arrangements.

VENCorp does not have an obligation to augment the network to provide the level of power transfer capability requested where it will not be able to recover the costs of that augmentation from the connection applicant or network users in accordance with Chapter 6 of the NER.

4. When an increase in the power transfer capability of the network is requested in a connection application, VENCorp, based on good engineering practices, may elect to undertake a preliminary assessment as to whether an augmentation to achieve that increase in capability is likely to satisfy the regulatory test. The connection applicant will fund the preliminary assessment.
5. If that preliminary assessment indicates that the augmentation is:
  - a. reasonably likely to satisfy the regulatory test, VENCorp may elect to proceed with an assessment of the augmentation against the regulatory test in accordance with the provisions of clause 5.6 of the NER; or
  - b. unlikely to satisfy the regulatory test, the connection applicant will have the option of funding the augmentation, subject to satisfaction of the requirements of the funded augmentation provisions of the NER.

VENCorp has an obligation to use 'reasonable endeavours' to provide generator access arrangements requested by a generator, which may be requested at any level of power transfer capability between zero and the maximum power input of the generator's generating units.<sup>20</sup> Similarly, VENCorp has an obligation to use its 'reasonable endeavours' to provide other connection applicants with an offer to connect that is consistent with the reasonable requirements of such a connection applicant, including with respect to the level and standard of power transfer capability that the network will provide.<sup>21</sup>

---

<sup>20</sup> Clause 5.5(d) of the NEC provides that a generator may seek generator access arrangements at any level of power transfer capability between zero and the maximum power input of the generator's generating units or group of generating units. Clause 5.5(e) requires an NSP to use reasonable endeavours to provide the generator access arrangements being sought by the generator subject to those arrangements being consistent with good electricity industry practice considering the matters set out in that clause.

<sup>21</sup> Clause 5.3.6(d) of the NEC provides that a NSP must use its reasonable endeavours to provide the connection applicant with an offer to connect in accordance with the reasonable requirements of the connection applicant, including without limitation, the location of the proposed connection point and the level and standard of power transfer capability that the network will provide.

The NER does not require VENCORP to augment the network to increase the network's power transfer capability to the level requested by the connection applicant where it will not be able to recover the costs of that augmentation from the connection applicant or network users in accordance with Chapter 6 of the NER.

Accordingly, an augmentation to increase the power transfer capability of the network may be funded in one of two ways:

- network users will fund any augmentation that has been subject to the clause 5.6 process and satisfies the regulatory test; or
- a connection applicant will fund the augmentation, in which case the requirements of the funded augmentation provisions of the NER apply.

It is consistent with its obligations under Schedule 5.1 of the NER for VENCORP to consider augmentations to increase the power transfer capability of the network. Therefore, when an increase in the power transfer capability of the network is requested in a connection application, VENCORP may elect to undertake a preliminary assessment of the whether the augmentation is reasonably likely to satisfy the regulatory test. The connection applicant will fund this assessment.

A preliminary assessment undertaken by VENCORP would not involve a detailed and accurate assessment of the market benefits and costs of the augmentation and alternative options. Where this preliminary assessment identifies that an augmentation is reasonably likely to satisfy the regulatory test, VENCORP may elect to proceed with an assessment of the augmentation against the regulatory test in accordance with the provisions of clause 5.6 of the NER.

VENCORP cannot provide positive assurances as to the actual outcome of the regulatory test assessment in accordance with clause 5.6 of the NER based on the preliminary assessment, as VENCORP's preliminary assessment will not involve a detailed and accurate assessment of the market benefits and costs of the augmentation and alternative options. Therefore, the connection applicant that requests VENCORP proceed with an assessment of a power transfer capability augmentation against the regulatory test in accordance with clause 5.6 of the NER must accept the risk that an augmentation may not ultimately satisfy the regulatory test.

Further, the connection applicant should carefully consider how its project would be treated under the regulatory test should VENCORP assess an augmentation for an increase in the network's power transfer capability. It is likely that, at the time of a regulatory test assessment, the connection applicant's project would be an anticipated project for the purposes of the regulatory test<sup>22</sup>. In contrast to a committed project, which is an element of each and every reasonable scenario for the purposes of applying the regulatory test, an anticipated project is only an element of those reasonable scenarios representing market development scenarios in which it is likely to occur.

A connection applicant that is not prepared to wait for the clause 5.6 processes to be completed in respect of an augmentation to increase the power transfer capability of the network will have the option of funding an augmentation to increase the power transfer capability of the network. Alternatively, it could elect to operate with a lower transfer capability.

In the event that a connection applicant wishes to fund an augmentation to increase the power transfer capability of the network, the requirements of the funded augmentation provisions of the NER must be satisfied.

#### **4.3 Incremental augmentations to the network**

- 6. Subject to the preliminary program agreed by VENCORP and the connection applicant, if in VENCORP's reasonable opinion there may be market benefits from undertaking additional augmentation works over and above those comprising the network augmentation which would suffice to:
 
  - a. ensure a new connection applicant satisfies either a minimum, automatic or negotiated access standard; or**
  - b. increase the power transfer capability of the system to the level requested by a new connection applicant,****

**VENCORP may apply the regulatory test to the costs and market benefits of that incremental augmentation.**

- 7. Where an incremental augmentation is constructed, which is comprised of works that are not required by a connection applicant, the connection applicant**

---

<sup>22</sup> For the purposes of the regulatory test, an 'anticipated project' is a project that does not meet each of the criteria for a 'committed project' and is in the process of meeting one or more of the criteria for a 'committed project'. A 'committed project' is a project for which all regulatory consents and approvals have been obtained, construction has commenced or a firm commencement date has been set, relevant land rights have been acquired, construction and supply contracts have been executed and financing arrangements have been finalised and executed.

**will fund only such costs as are associated with the augmentation works that facilitate its connection.**

Transmission investments typically exhibit economies of scale. That is, the incremental cost of adding an additional unit of capacity diminishes as the size of the augmentation increases. Therefore, there may be circumstances where it is beneficial, from a whole of market perspective, for additional augmentation works to be undertaken over and above those comprising the augmentation that would suffice to facilitate the entry of a specific connection applicant.

Accordingly, where it is possible to identify incremental augmentation works that would constitute an 'option' for the purposes of the regulatory test (an 'incremental augmentation'), VENCORP may deem that it is prudent and in accordance with good industry practice to consider whether such an incremental augmentation would be reasonably likely to satisfy the regulatory test and should be assessed against the regulatory test in accordance with clause 5.6 of the NER. For example, where during a connection application process it is identified that an augmentation may be required to enable the connection applicant to satisfy either a minimum, automatic or negotiated access standard, VENCORP may consider whether an incremental augmentation would be likely to be beneficial for the market and should be assessed against the regulatory test in accordance with clause 5.6 of the NER.

In doing this, VENCORP would consider whether there are identifiable benefits of proceeding with the incremental augmentation and whether the benefits of that incremental augmentation are likely to be greater than the cost of the incremental augmentation.

Similarly, if a connection applicant wishes to fund an augmentation to increase the power transfer capability of the network, VENCORP may consider the merits of constructing an incremental augmentation.

Whether VENCORP will be able to proceed with an assessment of an incremental augmentation in accordance with the clause 5.6 processes will be contingent on the preliminary program for connection agreed by the connection applicant. A connection applicant may be unwilling to delay connection to provide VENCORP with the time to undertake the detailed regulatory test assessment process established by the clause 5.6 provisions of the NER.

The preliminary program provided by VENCORP will identify the timing and risks associated with proceeding down this path. The timing would also be contingent on the type of incremental augmentation under consideration by VENCORP. Augmentations defined as new small transmission network assets require a less extensive consultation process than augmentations defined as new large transmission network assets<sup>23</sup>. There is also no dispute avenue in the process for assessing a new small transmission network asset.<sup>24</sup>

Where VENCORP proceeds with an incremental augmentation, the cost of that incremental augmentation will be recovered from network users in accordance with Chapter 6 of the NER. The connection applicant will only be required to fund the costs of the augmentation that would suffice to facilitate its connection.

---

<sup>23</sup> A new small transmission network asset is defined as an asset of a *Transmission Network Service Provider* which is an *augmentation* and:

- (a) in relation to which the *Transmission Network Service Provider* has estimated it will be required to invest a total capitalised expenditure in excess of \$1 million, unless the *AER publishes* a requirement that an asset will be a *new small network asset* if it involves investment of a total capitalised expenditure in excess of another amount, or satisfaction of another criterion. Where such a specification has been made, an asset must require total capitalised expenditure in excess of that amount or satisfaction of those other criteria to be a *new small network asset*; and
- (b) is not a *new large transmission network asset*.

A new transmission large network asset is defined as an asset of a *Transmission Network Service Provider* which is an *augmentation* and in relation to which the *Network Service Provider* has estimated it will be required to invest a total capitalised expenditure in excess of \$10 million, unless the *ACCC publishes* a requirement that a *new large network asset* will be distinguished from a *new transmission small network asset* if it involves investment of a total capitalised expenditure in excess of another amount, or satisfaction of another criterion. Where such a specification has been made, an asset must require total capitalised expenditure in excess of that amount or satisfaction of those other criteria to be a *new transmission large network asset*.”

<sup>24</sup> Clause 5.6.6A sets out the process for consulting on the assessment of a new small transmission network asset in an annual planning report. Contrast the process set out in clause 5.6.6 for a new large transmission network asset, which establishes a dispute resolution process in respect of the contents, assumptions, findings or recommendations set out in a final report assessing the new large transmission network asset against the regulatory test (clause 5.6.6(h) to (j)).

#### 4.4 Non-discriminatory access to the network

VENCorp has an obligation to connect a connection applicant to the shared network regardless of the relative timing of any other applications to connect. Further, VENCORP recognises the desirability of providing access on similar terms regardless of the timing of connection.

8. It may be fair and reasonable for VENCORP to require as a term of connection that a connection applicant ('Connection Applicant 2') contribute to the costs of an augmentation funded by an earlier connection applicant ('Connection Applicant 1') in a fair and reasonable manner, where Connection Applicant 2 utilises that augmentation to ensure it meets an automatic, negotiated or minimum access standard.
9. Where VENCORP did so require, it would likely limit the imposition on Connection Applicant 2 of any obligation to contribute to the costs of augmentation to circumstances in which Connection Applicant 2 connects within a period of three years from the augmentation's commissioning date.
10. It would not be appropriate to adopt an analogous course in respect of any augmentation to increase power transfer capability funded by Connection Applicant 1 that benefits Connection Applicant 2 other than in respect of meeting an automatic, negotiated or minimum access standard.

VENCorp may assist two or more connection applicants to reach mutually beneficial commercial arrangements to fund an augmentation where each connection applicant consents to VENCORP disclosing limited information regarding the intended location, size, scope and timing of its proposed new connection to the other connection applicant(s).

- 11A Where VENCORP receives two or more applications to connect to the shared transmission network in a similar location within a similar timeframe, and a funded augmentation is required to facilitate any connection in that location, VENCORP will give the applicants the opportunity to decide how to allocate the augmentation costs via a multi-party negotiation process. VENCORP will offer a three month negotiation period in which to agree a proposal for allocation of the augmentation costs, to run from receipt of the second connection application or (if later) when the scope of works and cost estimate for the augmentation has been determined. If agreed, further applicants during the negotiation period may join the process.
- 11B If the applicants do not agree to the multi-party negotiation process or the negotiations fail, VENCORP may make offers to connect which include a cost allocation methodology determined by VENCORP, to apply in the event that multiple parties accept a connection offer by a specified date. This

**methodology may involve a fixed portion (e.g. based on installed capacity (MW)) and variable portion (e.g. based on energy consumed (MWh)).**

VENCorp has an obligation to connect a connection applicant to the shared network regardless of the relative timing of any other applications to connect or the terms of connection offered to a user that connected earlier in time.<sup>25</sup> Further, VENCorp recognises the desirability of providing access on similar terms regardless of the timing of connection.

However, as identified in section 2.3 there may be advantages or disadvantages of connecting earlier or later in time than another connection applicant, in the absence of appropriate arrangements to address any such advantages or disadvantages. Where the network is nearing its performance limit and a new connection will trigger the need for an augmentation to enable the connection applicant to meet an automatic, negotiated or minimum access standard, it may confer an advantage to connect after an earlier connection applicant has connected and funded the required augmentation.

By and large these issues will need to be addressed on a case by case basis and VENCorp is limited in what it can do to address any advantages or disadvantages conferred by the relative timing of connection applications. Nonetheless, VENCorp will endeavour to ensure that a connection applicant is not overly disadvantaged relative to other connection applicants by reason of the timing of its connection. This can be achieved in a number of ways depending on the circumstances.

Where an earlier in time connection applicant ('Connection Applicant 1') was required to fund an augmentation as a condition of connection to ensure that the connection applicant met an automatic, negotiated or minimum access standard, it may be fair and reasonable for VENCorp to require any subsequent connection applicant ('Connection Applicant 2') to contribute to the funding of that augmentation as a term of connection of Connection Applicant 2. VENCorp may consider that imposing conditions of this type is necessary to address the problem of 'free-riding' by Connection Applicant 2. 'Free-riding' would occur where the augmentation funded by Connection Applicant 1 also enables Connection Applicant 2 to meet an automatic, negotiated or minimum access standard. To prevent this 'free rider' problem and to ensure that the Connection Applicant 1 is not overly disadvantaged, Connection Applicant 2 may be required to contribute to the cost of the augmentation in a fair and reasonable manner to be determined by VENCorp.

The terms and conditions upon which Connection Applicant 2 was to contribute to the cost of the augmentation would be set out in its offer to connect and would depend upon the extent to which the augmentation facilitated the satisfaction of the technical requirements applicable to the connection of Connection Applicant 2. To ensure that such a process is administratively manageable, VENCorp would likely limit the imposition on Connection Applicant 2 of any obligation to contribute to the costs of the augmentation funded by Connection Applicant 1 to circumstances in which Connection Applicant 2 connected within three years of the augmentation's commissioning date. A three year timeframe is seen as

---

<sup>25</sup> In particular, an NSP must make an offer to connect under clause 5.3.6 of the NER.

administratively manageable given that changes in the network utilisation over a longer time frame make the allocation of charges to specific users problematic.

VENCorp does not consider it to be appropriate to adopt an analogous course in respect of any augmentation to increase power transfer capability funded by Connection Applicant 1 that benefits Connection Applicant 2 other than in respect of meeting an automatic, negotiated or minimum access standard. This is because Connection Applicant 1 would have elected to fund the augmentation to increase power transfer capability, based on an assessment of its commercial interests having regard to the potential for a further application to connect to the relevant line. It would not have been required to fund the augmentation as a term of connection. Accordingly, the imposition on Connection Applicant 2 of a requirement to contribute to the cost of the augmentation, as a term of connection, would create a disadvantage with respect to connecting later in time. Connection Applicant 2 would not have had the benefit of electing whether to fund an augmentation to increase power transfer capability that accrued to Connection Applicant 1.

Another option is to address any advantages or disadvantages conferred by the relative timing of connection applications at the time that a connection enquiry is received. At this time, VENCorp may assist two or more connection applicants to reach mutually beneficial commercial arrangements to fund an augmentation where each connection applicant consents to VENCorp disclosing information regarding the intended location, size, scope and timing of its proposed connection to the other proposed connection applicant(s). Where two or more new connection applicants are seeking to connect at a similar part of the network, there is scope for the construction of an augmentation which is mutually beneficial and lowers the total cost of connection for all connecting parties.

To facilitate such mutually beneficial arrangements, VENCorp may provide each of the connection applicants with a scope of works, a reasonable estimate of total cost of the works and a schedule of costs for the augmentation where one, two etc. connection applicants connect and, agree to fund that augmentation.

VENCorp will give the applicants the opportunity to negotiate how the augmentation costs will be allocated. The applicants will be offered a negotiation period of three months in which to reach agreement from the time of receipt of a second connection application or (if later) when the scope of works and cost estimate for the augmentation has been determined. Any agreement on cost allocation will first be reviewed for reasonableness by VENCorp before being accepted.

The applicants will also be required to provide VENCorp with a proposed methodology for determining how any future connecting parties, who connect within three years of the commissioning of the final negotiating applicant, should share the cost of the augmentations such that future connecting parties are not materially disadvantaged.

If the parties do not agree to the negotiation process, or are unable to agree to the allocation of augmentation costs within three months, VENCorp may make offers to connect which include a cost allocation methodology determined by VENCorp on a fair and reasonable basis, to apply in the event that multiple parties accept a connection offer by a specified date.

This methodology may involve a fixed portion (e.g. based on installed capacity (MW)) and variable portion (e.g. based on energy consumed (MWh)), and the augmentation costs will vary according to the number of connecting parties. If made by VENCORP, such an offer would be based on all available information at the time. Should one applicant not accept the offer by the date specified, or not proceed with connection, the remaining connection applicant(s) would be required to pay the costs of augmentation associated with their connections. These costs will still be subject to adjustment if any further parties connecting within three years are required to contribute to the costs of the augmentations.

VENCORP considers that its proposed negotiation approach has several advantages:

First, it provides all parties involved in the negotiation process with the opportunity to reach a mutually beneficial outcome by determining how much each individual party is willing to contribute to the augmentation. Not all connecting parties will have the same ability to fund the augmentations. Each party may therefore have an incentive to delay connecting and triggering the investment so as to “free-ride” on the investment undertaken by another party. The combined outcome may then be that the investment is inefficiently delayed indefinitely. However, it is likely that each party would be willing to contribute at least some amount to the augmentation. VENCORP believes that the negotiation process provides the parties with the appropriate forum to enable this to occur.

Second, because of the information asymmetries between VENCORP and the connecting parties on how much each is willing to contribute to the augmentation, VENCORP’s cost allocation methodology may be less attractive to one or more of the connection applicants than could have been achieved through the negotiation process. The methodology could affect both the timing of the initial investment decision, in a manner described previously, and/or the connection applicant’s ongoing operational behaviour in the market.

Finally, the negotiation process provides any potential applicants who are looking to connect to a similar part of the network in a similar timeframe, who have not already revealed their intention to connect except to VENCORP through a connection enquiry, with the incentive to come forward and join the negotiations. This will ensure that they are a party to the negotiation process and are not disadvantaged by not being included in the process.

#### 4.5 Bringing forward augmentations and partial funding

12. **VENCorp may consider bringing forward an identified network augmentation on the request of a connection applicant, provided:**
  - a. **bringing forward the augmentation does not result in any cost or risk to the market; and**
  - b. **VENCorp can fully recover the costs, at no risk, of the brought forward augmentation.**
13. **One approach that VENCORP may consider further is bringing forward the augmentation on the basis that the connection applicant meets any net costs associated with bringing the augmentation forward. In this instance, other network users would be indifferent between the augmentation being constructed at the original date forecast by VENCORP and the brought forward date.**

**However, satisfaction of the regulatory test by the brought forward augmentation and the recovery by VENCORP of the costs of that augmentation (net of those costs borne by the connection applicant) would depend on whether the partial funding of the brought forward augmentation by the connection applicant may be treated for the purposes of the regulatory test as either:**

- a. **a reduction in the "costs" of the brought forward augmentation; or**
- b. **an additional "market benefit" of the brought forward augmentation.**

There may be instances where VENCORP has identified the need for an augmentation in its Annual Planning Review (APR) which a connection applicant requests should be brought forward to coincide with its connection.

In principle, VENCORP is not opposed to bringing forward an identified augmentation if requested by a new connection applicant, or for that matter an existing market participant, provided that bringing forward the augmentation does not impose any cost on the market and VENCORP can fully recover the costs of the brought forward augmentation. As such, VENCORP may be prepared to consider the feasibility of bringing forward its regulatory test assessment if requested to do so.

The approach that VENCORP may be willing to consider would entail VENCORP conducting studies comparing the net present value of the market benefit (i.e. the present value of benefits less the present value of costs) of a number of alternative options to address the emerging network limitation. The option that satisfies the regulatory test is the option which maximises the net present value of the market benefit compared with a number of alternative options and timings in a majority of reasonable scenario (*optimal project*).

VENCorp could then compare the net present value of the market benefit for the *optimal project* with the net present value of the market benefit with the same or similar project at the brought forward commissioning date (*advanced project*).

The proponent seeking advancement of the optimal project could then be required to pay an amount equivalent to the “net cost” of bringing forward the option. The “net cost” of advancing the project would be calculated by taking the difference between the net present value of the market benefit for the *optimal project* and the net present value of the market benefit of the *advanced project*. Hence, the “net cost” determined in this manner includes a consideration of the impacts on costs and benefits that arise as a result of the advancement of the project.

The profile of payment of the “net cost” to be made would be the subject of negotiation with VENCORP. Payment terms may encompass options such as a once-off up front payment (on commissioning of the project), or a series of annual payments made over the advancement period. Regardless of the profile of payments, the present value of the payments made by the proponent would equate to the “net cost” of advancing the project.

This approach ensures that the market remains economically indifferent between the *optimal project* and the *advanced project*. This approach therefore represents a fair and reasonable approach from a whole of market perspective.

In assessing the *advanced project* against the regulatory test, in accordance with the relevant clause 5.6 provisions, the *advanced project* would satisfy the regulatory test if the *optimal project* would do so, provided the "net cost" payment may be treated for the purposes of the regulatory test as either:

- a reduction in the "costs" of the *advanced project*, or
- an additional "market benefit" of the *advanced project*.

It is only in these circumstances that the cost of the *advanced project* (net of the "net cost" payment made by the connection applicant) could be recovered by VENCORP from network users in accordance with Chapter 6 of the NER.

Accordingly, the feasibility of bringing forward an augmentation on the request of a connection applicant in the manner outlined above would depend on whether it could be demonstrated to the satisfaction of the AER that the "net cost" payment by that connection applicant should be treated as a reduction in the "costs", or additional "market benefit", of the *advanced project*.

Figure 5 presents a simplified example of the methodology that VENCORP may consider for bringing forward an augmentation subject to satisfactory resolution of the issues associated with assessing the *advanced project* against the regulatory test identified above.

FIGURE 5 SIMPLIFIED EXAMPLE OF BRINGING FORWARD AN AUGMENTATION

Assume that VENCORP identifies that a network limitation is likely to emerge in 5 years time. Assume also that there is only one project in this instance which is likely to address the constraint, the *optimal project*. Assume also that the market benefits of the *optimal project* are calculated to be \$40 million and that the *optimal project* will cost \$30 million to construct. In this case, the NPV of the market benefits of the *optimal project* is \$10 million.

A new connection applicant, or an existing market participant, requests that VENCORP bring forward the project such that the *advanced project* is identical in all respects to the *optimal project* except for the commissioning date. VENCORP's assessment identifies the cost of the *advanced project* would be \$31 million (e.g. technological improvements are expected to reduce the cost of the option in future years) and will deliver market benefits of \$35 million (e.g. the risk of load shedding is larger in the later years). The NPV of the market benefits of the *advanced project* is \$4 million.

Based on the NPVs of the *optimal project* and the *advanced project*, the "net cost" of advancing the project would be \$6 million and would be funded by the new connection applicant to facilitate its connection, or existing market participant, as a condition of bringing forward the *optimal project*.

	OPTIMAL PROJECT (\$MILLIONS)	ADVANCED PROJECT (\$MILLIONS)
Cost of option	30	31
Expected Market Benefits	40	35
Expected present value of the net market benefit	10	4
<b>Net Cost of advancing the project</b>	<b>6</b>	

All dollars would be calculated in present value terms at a common point in time.

## 5. WIND FARM CONNECTIONS

### 5.1 Wind developments in the NEM

The increasing number of large-scale wind farm developments has prompted both State and Commonwealth Governments and regulatory agencies to investigate issues associated with their connection to the national grid.

The Victorian State Government has established a target for up to 1,000 MW of Wind Energy to be located in Victoria by 2006 with a longer term goal to have 10% of Victoria's electricity consumption from renewable resources by 2010. To facilitate wind developments it introduced amendments into the Electricity Industry Act 2000 to enable the State Government to deem augmentations to the distribution network to be approved where they facilitate a connection for wind farms. It has also established a fund to which wind farms can apply for assistance with the costs of establishing new connections.

At the Commonwealth level, the Ministerial Council on Energy established a project, run by the Wind Energy Policy Working Group (WEPWG) to consider issues concerning the entry of renewable energy generation. The WEPWG released a discussion paper in March 2005 identifying a number of issues which it recommended needed to be addressed with urgency.

The South Australian Electricity Supply Industry Planning Council (ESIPC) identified similar issues in its report to the Essential Services Commission of South Australia (ESCOSA). ESCOSA requested that ESIPC assist it in its deliberations regarding the granting of electricity generation licences following the receipt of numerous wind farm proposals. The main additional recommendation was that NEMMCO must be able to automatically optimise unscheduled generators (as is currently done for scheduled generators) to ensure that the market continues to operate efficiently and securely.

### 5.2 Wind developments and new connections

- 14. A non-scheduled generator will be required by its connection agreement to install generation control equipment, if VENCORP deems it appropriate to ensure that the power system continues to operate securely and reliably.**
- 15. The terms of the non-scheduled generator's connection agreement will establish arrangements for managing network use on a fair and reasonable basis, if the combined generating capacity of non-scheduled generators exceeds, or is reasonably likely at some future time to exceed, the power transfer capability of the line to which they are or will be connected. In particular, these arrangements may provide for the generation of competing non-scheduled generators to be reduced on a fair and reasonable basis where**

**their combined output would otherwise exceed the power transfer capability of the line to which they are connected.**

Currently, the NER does not establish arrangements for managing network use by non-scheduled generators, such as wind developments. Therefore, VENCORP proposes to address network use by non-scheduled generators in Victoria through their terms of connection in the following manner to ensure VENCORP is able to effectively discharge its system security obligations.

Wind farm developments, as well as all other non-scheduled generators, will be subject to the arrangements set out in notes 1 to 12 of the Guidelines, as are all other new connection applicants. That is, they will be required to fund any augmentations to the shared transmission network required to enable their connection to meet the relevant access standards and can elect to fund an augmentation to the shared transmission network to increase or maintain a specified power transfer capability. This will ensure a consistent application of these Guidelines by VENCORP.

However, as has been identified by the MCE and ESIPC in their reports, referred to in item 4.1 above, wind developments present a number of additional problems. For example:

- Wind generation is non-scheduled and is not required to control its output, essentially providing it with priority market access over controllable generation;
- Wind generation, by its nature, provides variable output, potentially adversely affecting scheduling of generation in the NEM; and
- The NER's technical standards do not appropriately cover some of the technical issues created by wind farm characteristics.

The competitive impacts of wind generators on the dispatch process are not of relevance to VENCORP's responsibilities and functions under the NER. VENCORP's concerns relate to the system security implications of wind farms. In particular it must ensure that following the connection of a wind farm, the power system continues to operate securely and reliably.

To this end, VENCORP considers that there are occasions that warrant imposing additional obligations on wind farms by means of their connection agreements. One such requirement will be to require a wind farm to install generation control equipment as a term of its connection to ensure that network limitations are not violated.

An example of the circumstances in which this may be appropriate is where there are two or more wind generators connected to the same part of the network and their maximum combined generating capacity would exceed the power transfer capability of that line. In this case, if an augmentation cannot be justified under the clause 5.6 provisions on the basis of the regulatory test, and the wind generators do not elect to fund an augmentation to increase the power transfer capability of the line, the terms of their connection will provide for the generation of those wind generators to be reduced on a fair and reasonable basis to be

specified in the connection agreement where their output would otherwise exceed the power transfer capability of the line to which they are connected.

There may be other occasions where VENCORP deems it appropriate to ensure the output of a wind farm is controllable. For example, where only one wind farm is connecting to the transmission network but VENCORP anticipates that there is a reasonable likelihood of additional wind farms connecting in future which may give rise to the problems identified above, VENCORP may include terms in the connection agreement of that first-mentioned wind farm that establish fair and reasonable arrangements for managing network use by non-scheduled generators in the event that this is necessary at some future time.

VENCORP will continually assess its approach to the connection of wind farms to ensure the integrity of the system is maintained now and in the future. It will also continue to monitor developments in other jurisdictions to ensure that these Guidelines are in keeping with best practice on non-scheduled generator developments.

## APPENDIX 1 NATIONAL AND INTERNATIONAL COMPARISON OF CONNECTION POLICIES

ISSUE	VICTORIAN DNSPS	ONTARIO ENERGY BOARD (CANADA)	HYDRO-QUEBEC (CANADA)	NATIONAL GRID (UK)	CER (IRELAND)	FERC (US)	PJM (US)
<b>New Connection</b>		Shallow Connection	Deep Connection	Shallow Connection	Shallow Connection	Deep Connection	Deep Connection
	User pays the costs (based on least cost-technically acceptable) less any revenue received by the network for that connection	User (generator) pays for all equipment for a connection.  Load customers can pay all costs for the connection or accept the 'pool funded' option.	User pays for least cost – technically acceptable as well as for any changes to project.	User pays all costs for connection, including assets affected by the connection	User pays for full cost, including a component of the capital and maintenance charges.	User pays full costs, including capital, maintenance and any additional works required for the connection	User pays full cost associated with a connection request
<b>Augmentation</b>	As above	As above	Transmission provider pays for augmentations for new load growth (except connection and metering)	Users pay for the practical minimum (least-cost, technically acceptable).	Any augmentations brought forward by a connection are recovered from use of system	User initially funds the upgrades, which are then reimbursed.	User pays for all connection costs necessary to accommodate that connection.

ISSUE	VICTORIAN DNSPS	ONTARIO ENERGY BOARD (CANADA)	HYDRO-QUEBEC (CANADA)	NATIONAL GRID (UK)	CER (IRELAND)	FERC (US)	PJM (US)
			<p>equipment) up to a maximum amount, after which the user pays the difference</p> <p>The maximum amount is based on the expected revenue.</p>		charges.		
<b>Additional Works during augmentation or connection</b>	As above - user pays	As above – user pays	As above – user pays	As above – user pays	Any additional work carried out by the Transmission provider above the practical minimum is not paid for by the connecting party.	As above – User funds and is then reimbursed.	User pays any incremental costs in bring a project forward or changes associated with a planned project.

<b>ISSUE</b>	<b>VICTORIAN DNSPS</b>	<b>ONTARIO ENERGY BOARD (CANADA)</b>	<b>HYDRO-QUEBEC (CANADA)</b>	<b>NATIONAL GRID (UK)</b>	<b>CER (IRELAND)</b>	<b>FERC (US)</b>	<b>PJM (US)</b>
<b>Rebates</b>	Load customers receive rebates if additional customers connect to	No comment	No comment	No comment	Users are rebated if another party connects using the same assets within 10 years	Users may be rebated if another facility connects and uses the network upgrades. No time limit identified.	No comment
<b>Disconnection Charges</b>	User pays any costs associated with the disconnection, which may include lost revenue (depending on user size)	No comment	No comment	User is charged any costs associated with disconnection.	No comment	User pays all costs associated with disconnection.	Customer is responsible for any charges that arise out of a default situation.
<b>Generation Policies</b>	Pricing policies	No comment	Ontario requires generators to	Pricing policies are the same	Pricing policies	Pricing policies are the same	Policies are the same for all

ISSUE	VICTORIAN DNSPS	ONTARIO ENERGY BOARD (CANADA)	HYDRO-QUEBEC (CANADA)	NATIONAL GRID (UK)	CER (IRELAND)	FERC (US)	PJM (US)
<b>(scheduled / unscheduled)</b>	as above Technical policies to cover scheduled and unscheduled generation		fully fund all modifications, enhancements and reinforcements of the system to accommodate the connection (Deep Connection).	for all connections, but technical requirements are being reviewed for unscheduled generation.	as above Specific technical section of Grid Code for wind farms.	for all connections, but technical requirements are being reviewed.	generators, but technical requirements vary for small generators or unscheduled generators.
<b>Queuing</b>	Not normally relevant	No comment	No comment	No comment	No comment	The queue position is established based on the date and time a request is received	Requests received within each 6- month period form part of a connection queue.
<b>Group Extension / Clustering</b>	Requests from multiple parties designed together and charges prorated	No comment	Connection costs are prorated if shared by more than one party.	No comment	A consultation is underway to group interacting wind farm connection	Groups of connection requests are studied as a group, rather than serially, for	No specific comment - It seems that requests within each 6-month block may be

ISSUE	VICTORIAN DNSPS	ONTARIO ENERGY BOARD (CANADA)	HYDRO-QUEBEC (CANADA)	NATIONAL GRID (UK)	CER (IRELAND)	FERC (US)	PJM (US)
	according to location and load				proposals.	impact studies and costs are prorated.	treated as a group, if the connection point is the same.